

VGF GLASS FASTENER ATTACHMENT GUIDE - FOR SOCKET DRIVE SCREWS

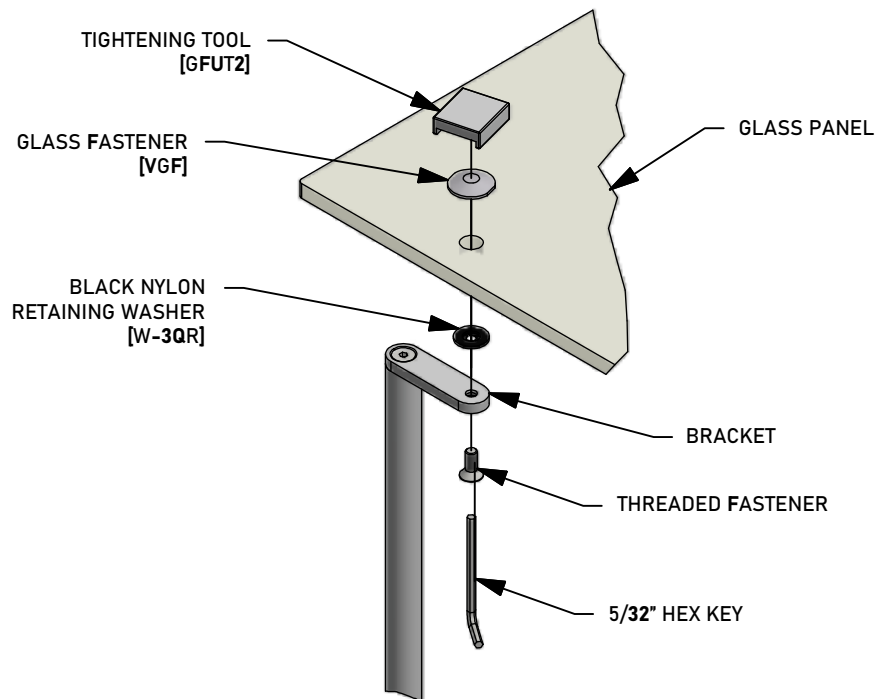

1. INSERT THREADED FASTENER INTO THE HOLE IN THE BRACKET FROM THE COUNTERSUNK SIDE OF THE BRACKET. PLACE A BLACK NYLON RETAINING WASHER **[W-3QR]** DOWN OVER THREADED END OF THE FASTENER ON OPPOSITE SIDE OF THE BRACKET. ENSURE POCKET SIDE OF WASHER IS FACING GLASS.
2. PLACE GLASS PANEL INTO POSITION OVER THE EXPOSED THREADED FASTENER SO THE THREADS PROTRUDE THROUGH THE MATING HOLE IN THE GLASS PANEL.
3. SCREW ON GLASS FASTENER **[VGF]** BY HAND. REPEAT FOR ALL BRACKETS. ADJUST GLASS POSITION BY LOOSENING FASTENERS, MOVING GLASS AND HAND-TIGHTENING THE GLASS FASTENERS **[VGF]** AS NEEDED.
4. WHEN SATISFIED WITH THE GLASS ALIGNMENT, INSERT THE SUPPLIED 5/32" HEX KEY FROM THE TOOL KIT INTO EACH FASTENER HEAD AND TIGHTEN WHILE HOLDING THE SUPPLIED TIGHTENING TOOL **[GFUT2]** TO THE TOP OF THE GLASS FASTENER **[VGF]** WITH YOUR HAND.
5. WHILE APPLYING PRESSURE TO THE GLASS FASTENER **[VGF]** WITH THE TIGHTENING TOOL, TIGHTEN THREADED FASTENER(S) BY USING 5/32 HEX KEY UNTIL FIRM.